

## TILT BEFORE TURN

### ● SYSTEM:

JTC2000 71 mm front-to-back dimension

### ● FABRICATION:

To BS 4873, CE marked DOP No. EL75-CW/01

### ● GLAZING SYSTEM:

**STANDARD:** Internally beaded

### ● PROFILES:

**STANDARD PROFILED:** F: APE9020, M/T: APE9050, V: APE9030

### ● DRAINAGE:

**STANDARD:** Through drainage. **ALTERNATIVE:** Face drainage

### ● INSULATING GLASS UNITS:

**STANDARD:** 28mm overall thickness, clear, low emissivity soft-coat to one pane, swiss spacer, argon filled:  
4mm diamant/16 swiss V/4mm Planitherm total +  
This will achieve BFRC energy rating WER Band B

### ● MAXIMUM MANUFACTURING SIZE:

**Max:** (W) 2500mm

**Min:** (H) 600mm

**Max:** (W) 1500mm

**Min:** (H) 450mm

Sizes are vent frame not outerframe

Weight restrictions also apply

### ● OPERATING GEAR: *Refer to technical department for further details/information*

Hardware	Standard	Alternative	Options
Hinges	Giesse TBT concealed hinges	None	None
TBT handles	TBT handles	None	None

### NOTES:

Trickle vent through APE6091 add-on

### CILLS:

APE3001 (30 x 95)  
APE3002 (30 x 155)  
APE3004 (45 x 155)  
APE3005 (45 x 190)

### ADD-ONS/COUPLERS:

APE6091

## TILT BEFORE TURN

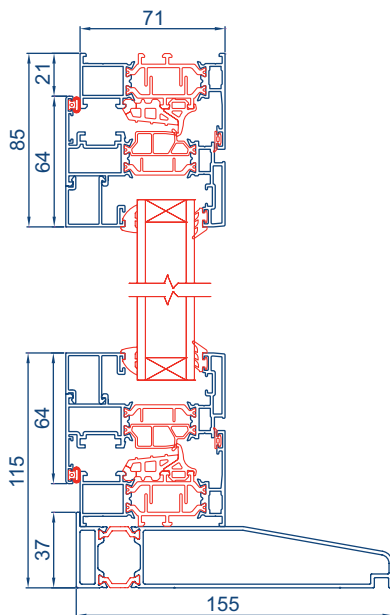
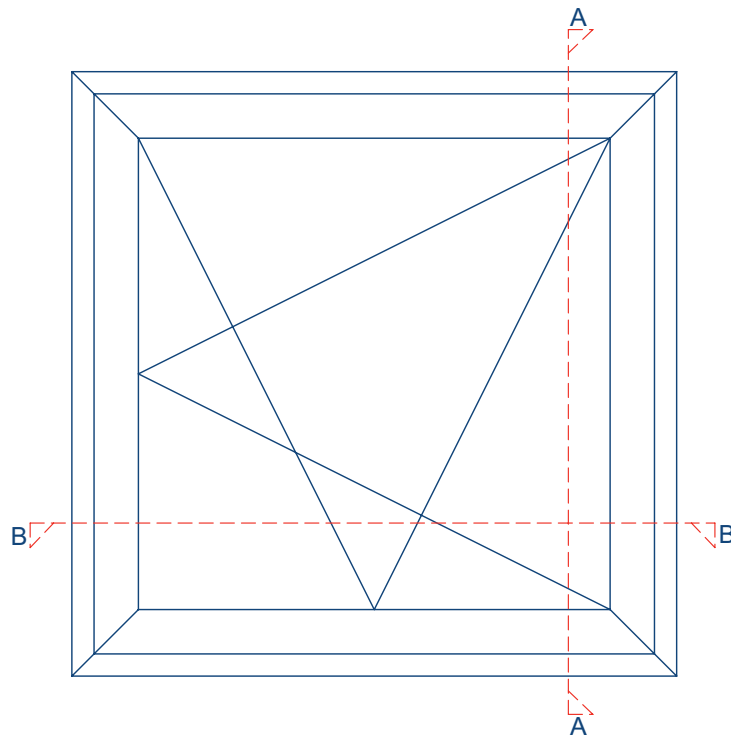

**DETAIL A-A**

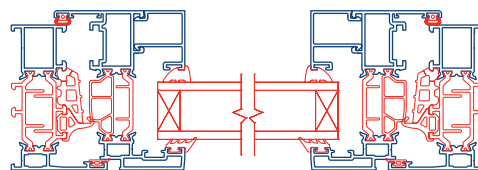

**DETAIL B-B**

## TILT BEFORE TURN

### ● FRAME PROFILES

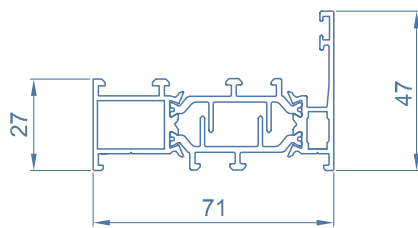

APE 9020 @5000mm  
OUTER FRAME

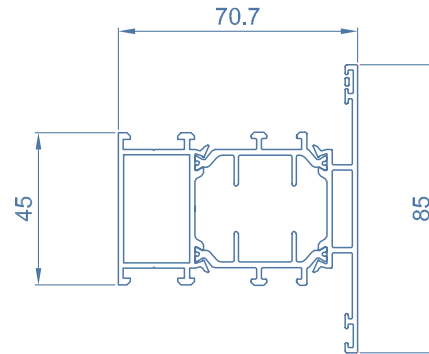

APE 9050 @5000mm  
MULLION/TRANSOM

### ● VENT PROFILES

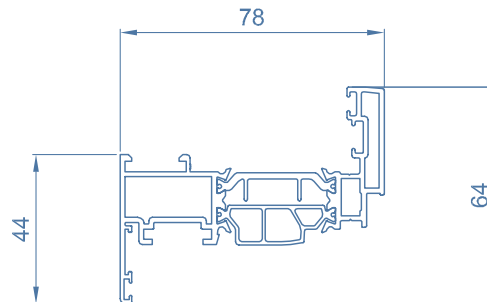

APE 9030 @5000mm VENT

### ● BEAD SELECTION

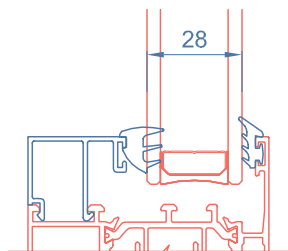

APE 9051 @5000mm

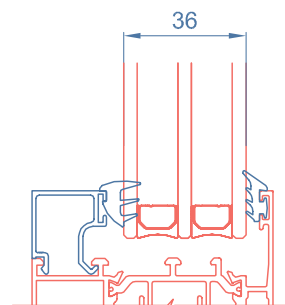

APE 9052 @5000mm